

LUMA Family Catalog 2010

Professional LCD Monitor

SONY
make.believe



LUMA
Professional LCD Monitor

Sony Offers Future-proof LUMA Series Professional Monitors with Stable Color Consistency Features



// High-grade type page4

Sony enhances its LUMA Series professional monitor lineup all the way from mid-level to entry-level, with LMD-4250W, LMD-2451W, LMD-2050W, LMD-1751W, and LMD-940W monitors at the top of this spectrum, and LMD-2030W and LMD-1530W monitors at the entry point.

The LUMA high-grade type monitors incorporate a wide viewing angle LCD panel, high-purity color filters, sophisticated 10-bit signal processing, and Sony's unique ChromaTRU color matching technology. With these qualities, they deliver precise images and accurate color reproduction for broadcast and professional video monitoring. Added to this, a newly supported white balance calibration function*¹ allows quick and simple monitor adjustment and matching, and offers stable color reproduction. And these LUMA high-grade monitors*² incorporate a 3G-SDI capability which means they can accept Y/Cb/Cr 4:2:2 1080/50p and 60p video signals using only a single SDI cable.

LUMA entry-level monitors, incorporating high-purity RGB color filters and a 10-bit*³ signal processing engine, offer stunning 109% peak white reproduction without clipping, and a smooth gray scale along CRT-like gamma. While these capabilities are appropriate for professional use, this type of LUMA monitor is also suited for use with consumer video and digital camera products – each is equipped with an HDMI connector. These monitors are therefore ideal for both professional and semi-professional high-definition applications.

This broad and powerful LUMA Series professional LCD monitor lineup continues to meet a variety of picture monitoring applications from broadcast and post-production to surveillance, and to demanding semi-professional applications.

*¹The LMD-2451W and LMD-1751W only. The LMD-940W supports from a version 1.05 or later.
This works with the combination of a PC and a commercially available calibration tool (X-Rite i1 Pro).
*²The LMD-2451W, LMD-1751W, and LMD-940W only.
*³The LMD-1530W only.



High-grade Type

LUMA high-grade type monitors incorporate a wide viewing angle LCD panel, high-purity color filters, sophisticated 10-bit signal processing, and Sony's unique ChromaTRU color matching technology. With these qualities, they deliver precise images and accurate color reproduction for broadcast and professional video monitoring. Added to this, a newly supported white balance calibration function*¹ allows quick and simple monitor adjustment and matching, and offers stable color reproduction. And these LUMA high-grade type monitors*² incorporate a 3G-SDI capability which means they can accept Y/Cb/Cr 4:2:2 1080/50p and 60p video signals using only a single SDI cable.

*1 The LMD-2451W and LMD-1751W only. The LMD-940W supports from a version 1.05 or later.
 This works with the combination of a PC and a commercially available calibration tool (X-Rite i1 Pro).
 *2 The LMD-2451W, LMD-1751W, and LMD-940W only.

// Five Panel Sizes

Model Types

	LMD-4250W	LMD-2451W	LMD-2050W	LMD-1751W	LMD-940W
Panel size (diagonal)	42-inch	24-inch	20-inch	17-inch	9-inch
Resolution	1920 x 1080	1920 x 1200	1680 x 1050	1280 x 768	800 x 480
Aspect ratio	16:9	16:10	16:10	15:9	15:9
Desktop stand	N/A	Supplied	Supplied	Optional SU-561	Supplied
EIA 19" rack mount	N/A	N/A	Optional MB-529	Optional MB-530	Optional MB-531
VESA mounting (mm)	400 x 400	100 x 100	100 x 100	100 x 100, 75 x 75	N/A



LMD-4250W



LMD-2451W



LMD-2050W



LMD-1751W



LMD-940W

Extremely Wide Viewing Angle

LUMA high-grade type monitors offer stable images when viewed from various angles: both horizontally and vertically, with virtually no reduction in picture contrast, color saturation, or hue shift. This allows precise images to be clearly viewed from various positions and angles – a critical requirement in professional video monitoring – and makes these monitors suitable for group viewing.



Superb Picture Performance

High Purity Color Filters

LUMA high-grade type monitors use precisely manufactured RGB color filters, allowing the reproduction of colors with stunning depth and saturation to create highly natural images.

Accurate Gamma and Stable White Balance - ChromaTRU™ Color Processing

For an extra level of color-reproduction accuracy, every LCD panel used in LUMA high-grade type monitors is precisely color calibrated at the factory, providing characteristics consistent with those of CRT displays.



The colorimetry of an LCD display, by nature, can exhibit inaccurate R, G, B color coordinates and unbalanced R, G, B gamma curves, which can make precise color matching between multiple monitors a challenge. These are also the primary reasons why LCD color tone can differ slightly from CRT tone. LUMA high-grade monitors solve this problem by precisely calibrating each LCD panel's light output so that the R, G, B color coordinates are virtually the same as those of a CRT monitor. A second calibration is further applied so that white balance is maintained at a consistent color temperature throughout all grayscale levels. The result of these precise calibrations is color reproduction reminiscent of Sony's CRT displays.

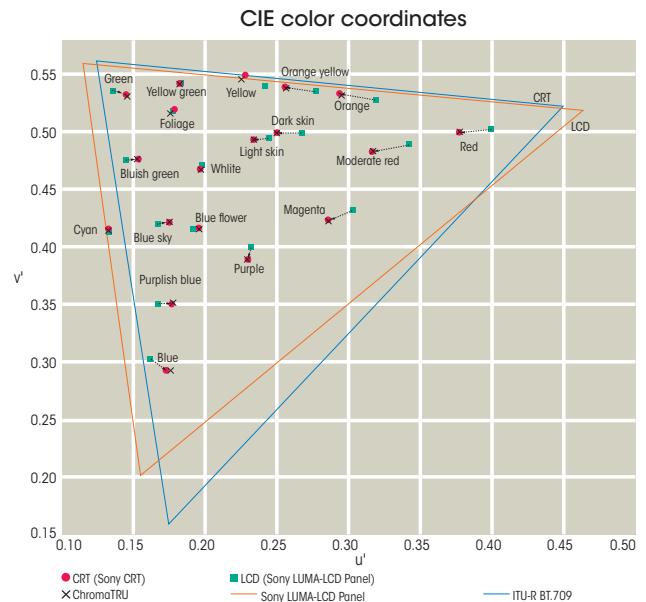

In this diagram, the raw light output of a LUMA LCD panel is compared with that of a CRT from Sony using a CIE u' v' chart, which enables evaluation of light output from display devices. The triangular areas show their different color reproduction capabilities (Color Space). The green and red dots indicate the color of light output from the LUMA LCD panel and from the CRT for certain RGB input signals. Note that the same light color is not obtained from the same video input. The ChromaTRU process, on the other hand, reproduces consistent light output extremely close to that of a CRT.

White Balance Calibration Function

LUMA high-grade monitors are adjusted at the factory to achieve optimized color, brightness, and gamma prior to shipment. LCD monitor performance, however, typically changes over time and requires regular recalibration to maintain its original performance.

The LMD-2451W, LMD-1751W, and LMD-940W*1 employ a software-based white balance calibration function, which is called LMD_AutoWhiteBalance. Combined with a PC and commercially available calibration tool*2, this function enables simple adjustment of the monitor's white balance.

*1 LMD-940W from a version 1.05 or later
 *2 The X-Rite Eye-one (i1) Pro Series.



LMD-1751W with white balance probe (X-Rite i1 Pro)

I/P Mode Selection

LUMA high-grade type monitors provide three I/P modes so that users can select the most suitable mode for each purpose:

- **INTER-FIELD:** This mode interpolates images between fields. This is used for picture quality precedence (e.g., to reduce the jagged effect on moving pictures).
- **FIELD MERGE:** This mode combines lines alternately in odd and even fields, regardless of picture movements. This is used for PsF (Progressive Segmented Frame) processing and still image monitoring.
- **LINE DOUBLER:** This mode interpolates by repeating each line. This is used for editing and monitoring fast-moving images, and checking line flicker. The minimum processing time is less than one field (0.5 frames).

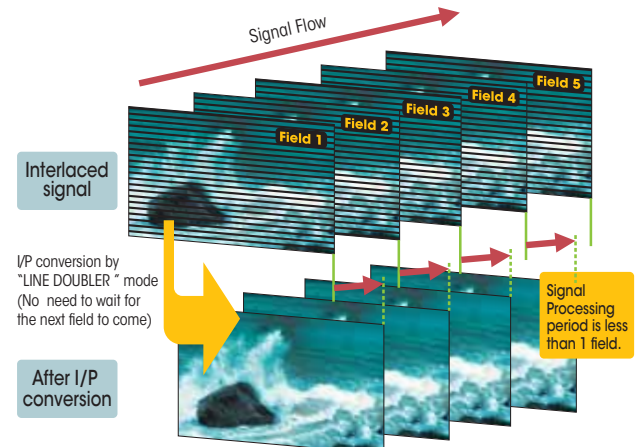

Input Versatility

Multi-format Signal Support – up to 3G-SDI Input

LUMA high-grade type monitors accept almost any SD or HD video format, both analog and digital. These include composite NTSC and PAL, component 480/60i and 575/50i, progressive 480/60p and 576/50p, and high-definition 1080/60i, 1080/50i, 720/60p, 1080/24p, 1080/25p, 1080/30p, 1080/24PsF, and 1080/25PsF. The LMD-2451W, LMD-1751W, and LMD-940W can also accept 1080/50p and 1080/60p 4:2:2 Y/Cb/Cr 10-bit formats from the 3G-SDI input*¹.

Standard interfaces on LMD-4250W, LMD-2451W, LMD-2050W, and LMD-1751W monitors include analog composite (NTSC/PAL), 525i/625i component and RGB, and Y/C. More inputs can be added by using option boards. Digital interfaces including HD-SDI and SD-SDI are also offered as optional boards, to meet all budgetary and user needs.

LUMA high-grade type monitors accept various types of analog and digital computer signal via standard HD15 and DVI-D*² interfaces, respectively. With their high-performance scan converters, these monitors can display PC signals from VGA to Full HD*³.

To provide mobility, the LMD-940W incorporates various video interfaces as standard, including a composite, SDI interface*⁴ for SD-SDI, HD-SDI, and 3G-SDI, and an HDMI interface.

*¹ The LMD-2451W and LMD-1751W require an optional BKM-250TG input adaptor for the 3G-SDI input interface.

*² Both 1080/50p and 1080/60p signals are accepted. The images are down-converted for display on the LMD-2050W, LMD-1751W, and LMD-940W.

*³ Images ranging from WSXGA+ to 1920 x 1080 are down-converted for display on the LMD-2050W and LMD-940W.

*⁴ SD-SDI, HD-SDI, and 3G-SDI inputs share the same BNC connector, and these signals are automatically detected.

3G-SDI Input

Sony's 3G-SDI interface is compliant with the SMPTE 425 standard, transmitting up to 4:2:2/10-bit 1080/60p and 1080/50p video data using one SDI cable. When an upgrade to these 1080/p systems is required, this single-link 3G-SDI system is an ideal, future-proof solution.



LMD-2451W with the BKM-250TG 3G-SDI board

Input signals / Input adaptors

Video Signal Formats	Input signals				LMD-4250W/LMD-2451W/LMD-2050W/LMD1751W					LMD-940W				
	Total Line	Active Line	Aspect Ratio	Frame Rate* ¹	Composite Y/C	RGB Component	SDI 4:2:2	HD-SDI SD-SDI	3G/HD/SD-SDI* ³	Composite	3G/HD/SD-SDI	HDMI		
					Standard					Options		Standard		
					BKM-227W	BKM-229X	BKM-220D	BKM-243HS BKM-244CC	BKM-250TG* ³					
575/50i (PAL)	625	575	16:9 & 4:3	25	○	○	○	○	○	○	○			
480/60i (NTSC)* ¹	525	483	16:9 & 4:3	30	○	○	○	○	○	○	○			
576/50p	625	576	16:9 & 4:3	50	N.A.	○	N.A.	N.A.	N.A.	N.A.	○			
480/60p	525	483	16:9 & 4:3	60	N.A.	○	N.A.	N.A.	N.A.	N.A.	○* ¹			
640 x 480/60p* ¹	525	480	4:3	60	N.A.	N.A.	N.A.	N.A.	N.A.	N.A.	○			
1080/24PsF* ¹	1125	1080	16:9	24	N.A.	○* ²	N.A.	○	○	N.A.	N.A.			
1080/25PsF	1125	1080	16:9	25	N.A.	○* ²	N.A.	○	○	N.A.	N.A.			
1080/24p* ¹	1125	1080	16:9	24	N.A.	○* ²	N.A.	○	○	N.A.	○			
1080/25p	1125	1080	16:9	25	N.A.	○* ²	N.A.	○	○	N.A.	○			
1080/30p* ¹	1125	1080	16:9	30	N.A.	○* ²	N.A.	○	○	N.A.	○			
1080/50i	1125	1080	16:9	25	N.A.	○	N.A.	○	○	N.A.	○			
1080/60i* ¹	1125	1080	16:9	30	N.A.	○	N.A.	○	○	N.A.	○			
720/50p	750	720	16:9	50	N.A.	○* ²	N.A.	○	○	N.A.	○			
720/60p* ¹	750	720	16:9	60	N.A.	○	N.A.	○	○	N.A.	○			
1080/50p	1125	1080	16:9	50	N.A.	N.A.	N.A.	N.A.	○	N.A.	○			
1080/60p* ¹	1125	1080	16:9	60	N.A.	N.A.	N.A.	N.A.	○	N.A.	○			

*¹ Compatible with 1/1.001 *² For component input only *³ LMD-2451W and LMD1751W only

Signal-interface Options

In addition to the standard input interfaces of analog composite, component and RGB, and Y/C (S-video), LMD-4250W, LMD-2451W, LMD-2050W, and LMD-1751W monitors are equipped with two slots for optional input adaptors of any combination for SD or HD video inputs. Users can expand their input capability according to their budget and needs.

Connector Panel

BKM-250TG

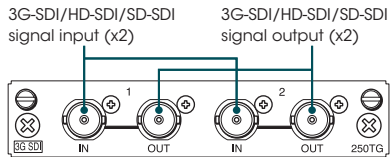

3G/HD/SD-SDI Input Adaptor

- 3G/HD/SD-SDI signal input (x 2)
- 3G/HD/SD-SDI monitor output (x 2)
- Power consumption: Approx. 4 W
- *3G-SDI, HD-SDI and SD-SDI signals are detected automatically.

BKM-243HS

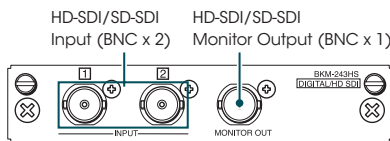

HD-SDI/SD-SDI Input Adaptor

- HD-SDI/SD-SDI signal input (x2)
- HD-SDI/SD-SDI monitor output (x1)
- Power consumption: 2.0 W
- *HD-SDI and SD-SDI signals are detected automatically.

BKM-229X

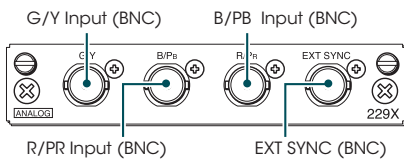

Analog Component Adaptor

- RGB/ Y/PB/PR input connector (x1)
- EXT SYNC (x1)
- Power consumption: 4.0 W

BKM-244CC

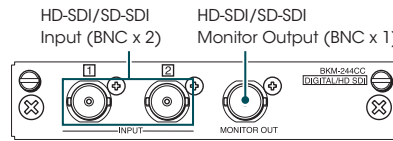

HD/SD-SDI Closed Caption Adaptor

- HD-SDI/SD-SDI signal input (x2)
- HD-SDI/SD-SDI monitor output (x1)
- Power consumption: 3.8 W
- *Both EIA 608 and EIA 708 Closed caption decoders are equipped.
- *HD-SDI and SD-SDI signals are detected automatically.

BKM-220D

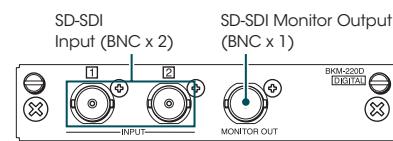

SD-SDI 4:2:2 Input Adaptor

- SD-SDI signal input (x2)
- SD-SDI monitor output (x1)
- Power consumption: 1.5 W
- *Embedded audio is supported.

BKM-227W

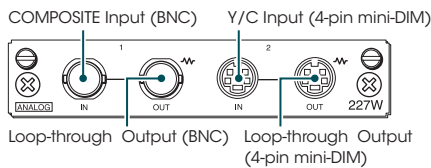

NTSC/PAL Input Adaptor

- Composite input/output (x1)
- Y/C input/output (x1)
- Power consumption: 1.8 W



LMD-2451W/LMD-2050W Connector Panel



LMD-940W Connector Panel



LMD-2451W/LMD-2050W Option Slots



LMD-1751W Connector Panel and Option Slots



LMD-4250W Connector Panel and Option Slots

Preset Computer Input Frequencies

LUMA high-grade type monitors* are factory preset to accept the following typical computer input signal frequencies:

* The LMD-940W monitor is not equipped with an HD15 interface.

HD15 Input Signal Format

Resolution	H Total	H addr.	V Total	V Addr.	Dot Clock [MHz]	fH [kHz]	fV [Hz]	Sync Polarity		LMD-4250W	LMD-2451W	LMD-2050W	LMD-1751W
								Horizontal	Vertical				
640x480@60Hz*	800	640	525	480	25.175	31.469	59.940	N	N	○	○	○	○
640x480@60Hz	800	640	494	480	23.625	29.531	59.780	P	N	○	○	○	○
720x400@70Hz*2	900	720	449	400	28.322	31.469	70.087	N	P	○	○	○	○
800x600@56Hz*	1024	800	625	600	36.000	35.156	56.250	P	P	○	○	○	○
800x600@60Hz*	1056	800	628	600	40.000	37.879	60.317	P	P	○	○	○	○
800x600@60Hz	960	800	618	600	35.500	36.979	59.837	P	N	○	○	○	○
800x600@72Hz*	1040	800	666	600	50.000	48.077	72.188	P	P	○	○	○	○
800x600@75Hz*	1056	800	625	600	49.500	46.875	75.000	P	P	○	○	○	○
800x600@85Hz*	1048	800	631	600	56.250	53.674	85.061	P	P	○	○	○	○
1024x768@60Hz*	1344	1024	806	768	65.000	48.363	60.004	N	N	○	○	○	○
1024x768@60Hz	1184	1024	790	768	56.000	47.297	59.870	P	N	○	○	○	○
1024x768@70Hz*	1328	1024	806	768	75.000	56.476	70.069	N	N	○	○	○	○
1024x768@75Hz*	1312	1024	800	768	78.750	60.023	75.029	P	P	○	○	○	○
1024x768@85Hz*	1376	1024	808	768	94.500	68.677	84.997	P	P	○	○	○	○
1152x864@75Hz*	1600	1152	900	864	108.000	67.500	75.000	P	P	○	○	○	○
1280x768@50Hz	1648	1280	791	768	65.125	39.518	49.959	N	P	○	○	○	○
1280x768@60Hz	1680	1280	795	768	80.125	47.693	59.992	N	P	○	○	○	○
1280x768@60Hz	1440	1280	790	768	68.250	47.396	59.995	P	N	○	○	○	○
1280x768@75Hz	1712	1280	802	768	102.875	60.091	74.926	N	P	○	○	○	○
1280x800@60Hz*1					68.900	48.935	59.969	N	N	○	○	○	○
1280x960@60Hz*	1800	1280	1000	960	108.000	60.000	60.000	P	P	○	○	○	○
1280x960@60Hz	1440	1280	988	960	85.250	59.201	59.920	P	N	○	○	○	○
1280x1024@60Hz*	1688	1280	1066	1024	108.000	63.981	60.020	P	P	○	○	○	○
1280x1024@60Hz	1440	1280	1054	1024	91.000	63.194	59.957	P	N	○	○	○	○
1360x768@50Hz	1760	1360	791	768	69.500	39.489	49.922	N	P	○	○	○	○
1360x768@60Hz	1776	1360	768	768	84.625	47.649	59.936	N	P	○	○	○	○
1360x768@60Hz	1520	1360	790	768	72.000	47.368	59.960	P	N	○	○	○	○
1600x1200@50Hz	2144	1600	1235	1200	132.375	61.742	49.994	N	P	○	○	○	○
1600x1200@60Hz	1760	1600	1235	1200	130.375	74.077	59.981	P	N	○	○	○	○
1920x1080@50Hz	2544	1920	1112	1080	141.375	55.572	49.975	N	P	○	○	○	○
1920x1080@60Hz	2080	1920	1111	1080	138.625	66.647	59.988	P	N	○	○	○	○

○ =VESA-DMT ○ =VESA-CVT VCRT N = Negative P = Positive * SOG *1 Anycast Station *2 Matrix

DVI-D input signal formats

	LMD-4250W	LMD-2451W	LMD-2050W	LMD-1751W
Vertical frequency	50.0 Hz to 85.1 Hz			
Horizontal frequency	31.5 kHz to 77.0 kHz			
Dot clock	25.175 MHz to 142.000 MHz	25.175 MHz to 148,500 MHz	25.175 MHz to 108.000 MHz	25.175 MHz to 141.000 MHz
Picture size, phase	Automatically detected by the DE (Data Enable) signal			

* The LMD-940W monitor is not equipped with a DVI-D interface.

Operational Convenience

Marker Settings

LUMA high-grade type monitors can display various area markers, including a center marker, aspect markers, and safety zone* marker. The brightness of these markers can be selected from three different levels: white, gray, and dark gray. Users can also select either a black or gray matte to fill the outer area of the aspect markers. These flexible marker controls, together with the choice of many different aspect markers, make LUMA high-grade type monitors extremely convenient display devices for a variety of shooting scenarios, from standard video acquisition to digital cinematography.

* The LMD-940W does not support the safety zone marker.

Marker settings

	16:9 Mode	4:3 Mode
Aspect Marker	4:3, 15:9, 14:9, 13:9, 1.85:1, 2.35:1, 1.85:1 & 4:3	16:9
Center Marker	Yes	
Safety Area	80%, 85%, 88%, 90%, 93%	



4:3 aspect marker image



16:9 aspect marker image

Waveform Monitor, Audio Level Meter, and Time Code Display*¹

The input signal's waveform with a 2-channel audio level meter can be displayed on screen. When an SDI interface is connected, the embedded audio level can be displayed on screen with an 8-channel audio level meter*². Installing an optional BKM-250TG 3G-SDI input adaptor, the LMD-2451W and LMD-1751W can display on screen a time code – either LTC or VITC is selectable.

*¹ LMD-2451W, LMD-2050W, LMD-1751W, and LMD-940W monitors support the on-screen audio level meter when they receive an SDI-embedded audio signal.

*² The LMD-940W displays on one side an 8-level audio level meter



Color Temperature

Color temperatures of D93, D65, or a user preset value can be selected.

Selectable Scan Size for Video Input and Aspect Ratio

Scan size can be selected between Normal scan, 5% over scan, Full scan, and Native scan modes*. The aspect ratio can be switched between 16:9 and 4:3 according to the input signal.

* Full scan and native scan modes work on specific signal formats.

Three-color Tally

The LMD-2451W, LMD-2050W, LMD-1751W, and LMD-940W are equipped with a tally lamp that can be lit via a parallel remote connector. The status of the signal displayed on the monitor can be identified by the tally color – red, green, or amber.

Smart APA (Auto Pixel Alignment) for Computer Input

The image size can be automatically adjusted to its optimal setting with the one-touch APA key.

* The LMD-940 has no computer signal input capability.

External Remote Control Function

LUMA high-grade type monitors have an external remote control capability for input/output signal selection and adjustment of various items via Ethernet (10BASE-T/100BASE-TX) connection. Up to 32 monitors and up to four control units can be connected via Ethernet connection and controlled remotely on the network. Users can control individual monitors or monitor groups simply by entering the monitor ID or group ID number. They can also execute the same operation on all connected monitors, or put all connected monitors into the same setup and adjustment state.

Power-saving Mode

When no input signal is received for over a minute, the monitor goes into power-saving mode and consumes minimal power. This function prevents unnecessary electrical consumption.

Stereo Audio Monitoring

LUMA high-grade type monitors* are equipped with stereo speakers (1.0 W + 1.0 W) and a stereo headphone jack, which enable users to monitor audio. The SDI-embedded audio can be monitored by the built-in speakers and the monitor output.

* The LMD-940W is equipped with a speaker (0.5 W) as well as a stereo headphone jack.

Protected Controls

With LUMA high-grade type monitors, the key-inhibit function helps prevent inadvertent operation from the control panel.

Closed-caption Decoder*¹

The closed caption information embedded in EIA 608 and EIA 708*² can be decoded for display.

*¹ The LMD-940W is not equipped with closed caption decoders.

*² For EIA708, the optional BKM-244CC Closed Caption Adaptor is required.

// Convenient Installation

Mounting Flexibility

The LMD-2050W and LMD-1751W are rack-mountable in the EIA 19-inch standard rack, using an optional MB-529 and MB-530 mounting bracket respectively.

*For LMD-940W mounting details, see page 10.



VESA® Mounting

LUMA high-grade type monitors provide VESA standard mounting holes which support installation on a wall or ceiling:

LMD-4250W – 400 x 400 mm pitch

LMD-2451W / LMD-2050W – 100 x 100 mm pitch

LMD-1751W – 100 x 100 mm and 75 x 75 mm pitch

// Other Features

- Multi-display mode
- H/V Delay Function
- ACC Off
- DC Operation
 - 24 V: LMD-2451W and LMD-2050W,
 - 12 V: LMD-1751W, and LMD-940W
- Setup Level for Analog Component and NTSC signal
- Sub Control on Contrast, Chroma, Phase, and Brightness
- Blue-Only Mode
- Monochrome Mode
- Auto Chroma/Phase Setup
- Power-saving Function

LMD-940W exclusive features and functions

The LMD-940W is a LUMA high-grade type high-performance monitor, and yet offers a convenient compact size with the mobility and smart functions required for both indoor and outdoor use.

// Stylish, Robust, and Compact Body

Incorporating a lightweight and compact aluminum die-cast body with a detachable AR-coated protection panel, this model is flexible enough to change style according to user requirements: with or without a stand (which is easily detachable), tilted on a stand (15-degree slant), rack-mounted, or set on a camera pedestal.



LMD-940W: variable styles

ENG Kit VF-510

The LMD-940W is a strategic choice for use in ENG and EFP field operations. Its picture contrast, compared to that of a CRT display, is less affected by ambient light, allowing clear images to be viewed even in strong sunlight. For further protection, the optional VF-510 ENG Kit provides a viewing hood, carrying handle, and connector protector.



LMD-940W with VF-510

Mounting Flexibility

The LMD-940W is 3.8 U high and a half-rack wide. Using the optional MB-531 mounting bracket with a 10-degree-forward and 10-degree-backward nonstop-tilt capability, two units can be installed side by side in a 19-inch EIA standard rack.



LMD-940W installed in the optional MB-531 19" mounting bracket with MB-532 mounting panel

Screw Holes for Camera Pedestal

With 3/8-inch and 1/4-inch screw holes on its base, the LMD-940W can be installed in a camera system. For example, it can be mounted on a camera pedestal.

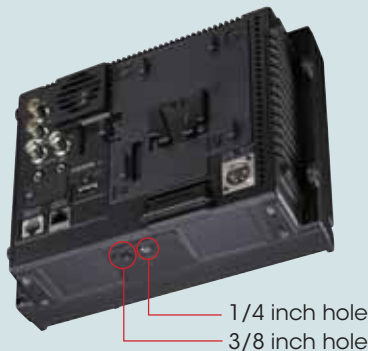

LMD-940W base with camera pedestal holes

Detachable AR (anti-reflection)-coated Protection Panel

The LMD-940W monitor uses robust AR-coated protection layers, which minimize the chance of the panel being scratched during transportation – an extremely important advantage in field use or in any mobile application. Added to this, the AR coating has two unique characteristics: it provides a high transmission rate of the internal light source to keep the picture as bright as possible, and it keeps reflection from ambient light to a minimum. As a result, when used in bright lighting conditions, high contrast is still maintained even in dark areas of the picture.



Protection panel

Excellent Picture Quality (NTSC/PAL video)

While designed for portable high-definition picture monitoring, the LMD-940W can also reproduce the most stunning NTSC/PAL composite images ever seen on a LUMA Series monitor, thanks to its WVGA (800 x 480) panel.

// Operational convenience

Camera Focus Function

The LMD-940W can control and increase the aperture level of a video signal, and display images on the screen with sharpened edges to help camera focus operation. This camera focus function can be even enhanced when combined with the native scan mode.



Marker Settings

The LMD-940W can display a center marker and aspect markers. The brightness of these markers can be selected from three different levels: white, gray, and dark gray. Users can also select either a black or gray matte to fill the outer area of the aspect markers. These flexible marker controls, together with the choice of many different aspect markers, make the LMD-940W an extremely convenient display device for a variety of shooting scenarios – from standard video acquisition to digital cinematography.

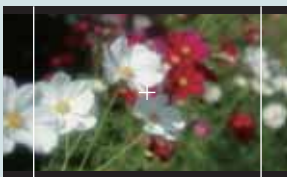

4:3 aspect marker image



16:9 aspect marker image

Waveform Monitor and Audio Level Meter Display*

An input signal's waveform with a 2-channel audio level meter can be displayed on screen. When an SDI interface is connected, the embedded audio level can be displayed on screen with an 8-channel audio level meter.

* The LMD-940 supports the on-screen audio level meter when it receives an SDI-embedded audio signal.



Waveform monitor

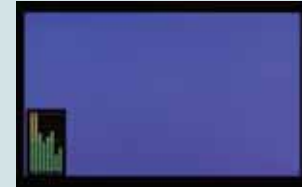

Audio level meter

Fan-motor Control Function

The LMD-940W automatically controls a fan-motor not to rotate at the normal temperature so that the monitor keeps noiseless during the operation.

Control Panel Design

The LMD-940W incorporates a new control panel design. By assigning monitor functions to each of its seven function buttons, users can customize the LMD-940W for a specific application or usage such as field or studio use. Seven functions can be allocated to the assignable buttons*. Button lights are dimmable and indicator lights are on/off switchable. This function allows users to easily operate a monitoring in a dark environment without interference of the lights.

* Factory default settings: brightness, contrast, chroma, scan, H/V delay, volume, and I/P mode.



LMD-940W

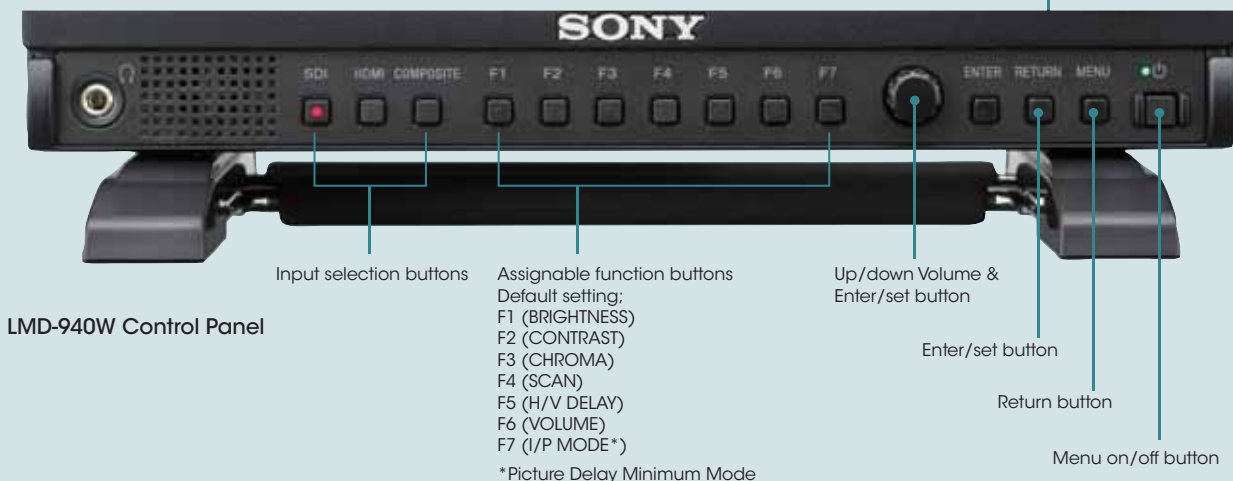

Entry-level Type

LUMA entry-level monitors, incorporating high-purity RGB color filters and a 10-bit* signal processing engine, offers stunning 109% peak white reproduction without clipping, and a smooth gray scale along CRT-like gamma. While these capabilities are appropriate for professional use, this type of LUMA monitor is also suited for use with consumer video and digital camera products – each is equipped with an HDMI connector. These monitors are therefore ideal for both professional and semi-professional high-definition applications.

* The LMD-1530W only.

//Two Panel Sizes

Model Types

	LMD-2030W	LMD-1530W
Panel size (diagonal)	20-inch	15.3-inch
Resolution	1680 x 1050	1280 x 768
Aspect ratio	16:10	15:9
Desktop stand	Supplied	Supplied
EIA 19" rack mount	Optional MB-529	Optional MB-533
VESA mounting (mm)	100 x 100	100 x 100



LMD-2030W



LMD-1530W

Wide Viewing Angle

The LCD panels used in entry-level LUMA monitors provide a wide viewing angle of 178 degrees for the LMD-2030W, and 176 degrees for the LMD-1530W, both horizontally and vertically, with minimal reduction in picture contrast. This allows images to be viewed from various positions and angles.



//High Picture Performance

High Purity Color Filters

Equipped with high-purity RGB color filters, LUMA entry-level type monitors achieve color reproduction with stunning depth and saturation.

Excellent Brightness and Contrast

LUMA entry-level type monitors provide high-brightness, high-contrast images thanks to their wide aperture LCD panels. In addition, the use of precisely manufactured RGB color filters allows these monitors to reproduce colors with stunning depth and saturation – creating highly natural images.

109% Peak White and 10-bit* Signal Processing

Incorporating high-purity RGB color filters and 10-bit signal processing engine, LUMA entry-level type monitors offer stunning 109% peak white reproduction without clipping and a smooth gray scale along CRT-like gamma.

* The LMD-1530W only.

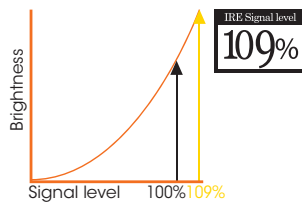

8-bit (256-levels) image



10-bit (1024-levels) image

Color Temperature/Gamma Selection

With entry-level type LUMA monitors, users can select from high, low, or preset color temperatures. A variety of gamma modes can also be selected.



Incorrect gamma image



Correct gamma image

I/P Mode Selection

LUMA entry-level type monitors provide two I/P modes so that users can select the most suitable mode for each purpose:

- INTER-FIELD: This mode interpolates images between fields. This is used for picture quality precedence (e.g., to reduce the jagged effect on moving pictures).
- LINE DOUBLER: This mode interpolates by repeating each line. This is used for editing and monitoring fast-moving images, and checking line flicker. The minimum processing time is less than one field (0.5 frames).

Picture Delay Minimum

Audio is just as much a part of the show as video, and timing is always an issue.

Picture Delay Minimum mode is selectable to minimize I/P conversion times for audio synchronization during editing. By selecting "LINE DOUBLER" in IP mode, the signal processing (I/P conversion) period is less than one field (0.5 frames).

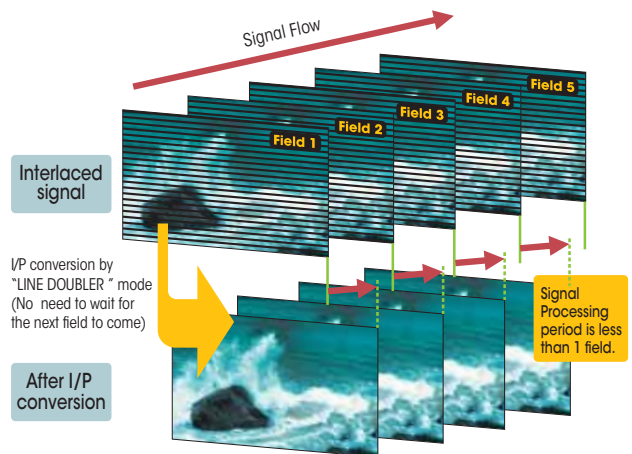

//Input Versatility

LUMA entry-level type monitors come equipped with a full range of analog SD inputs including analog composite NTSC and PAL, Y/C (S-Video), and 525i/625i component and RGB. These monitors can also handle SD-SDI input by using the optional BKM-320D SD-SDI input adaptor.

Furthermore, these monitors offer an HD signal input capability via their HDMI and analog component interface, and also can accept DVI signals via the HDMI interface*.

* A DVI conversion cable is required.

Video Input Signals/Input Adaptors

Input Signal				Interface			
System	Total Line	Active Line	Aspect Ratio	Composite Y/C	RGB Component	SD-SDI	HDMI
				Standard		Optional BKM-320D	Standard
575/50i (PAL)	625	575	16:9/4:3	○	○	○	○
480/60i (NTSC)*1	525	483	16:9/4:3	○	○	○	○
576/50P	625	576	16:9/4:3	N.A.	○	N.A.	○
480/60P	525	483	16:9/4:3	N.A.	○	N.A.	○
1080/24P*1	1125	1080	16:9	N.A.	○*2	N.A.	○
1080/25P	1125	1080	16:9	N.A.	○*2	N.A.	○
1080/30P*1	1125	1080	16:9	N.A.	○*2	N.A.	○
1080/50i	1125	1080	16:9	N.A.	○*2	N.A.	○
1080/60i*1	1125	1080	16:9	N.A.	○	N.A.	○
720/50P	750	720	16:9	N.A.	○*2	N.A.	○
720/60P*1	750	720	16:9	N.A.	○	N.A.	○

*1 The frame rate is also compatible with 1/1.001 frame rates. *2 Component signals only.

DVI Input Signals

Resolution	Dot clock (MHz)	fH (kHz)	fV (Hz)	LMD-2030W	LMD-1530W
720 x 400 70Hz	28.322	31.469	70.087	○	○
800 x 600 56Hz	36.000	35.156	56.250	○	○
800 x 600 60Hz	40.000	37.879	60.317	○	○
1024 x 768 60Hz	65.000	48.363	60.004	○	○
1280 x 768 60Hz	79.500	47.776	59.870	-	○
1360 x 768 60Hz	85.500	47.712	60.015	○	-

*A DVI conversion cable is required.

Connector Panel

LMD-2030W

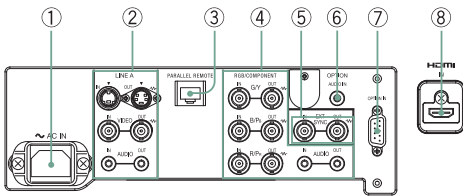

- ① AC In
- ② Line A [Composite (BNC), Y/C (Mini-DIN 4-pin), Audio (Phono jack)]
- ③ PARALLEL REMOTE (modular connector)
- ④ RGB/COMPONENT [BNC, Audio (Phono jack)]
- ⑤ EXY SYNC In/Out (BNC)
- ⑥ OPTION Audio In (Phono jack)
- ⑦ OPTION In connector for SD-SDI board (BKM-320D)
- ⑧ HDMI



LMD-2030W

LMD-1530W

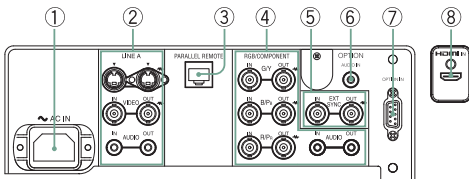

- ① AC In
- ② Line A [Composite (BNC), Y/C (Mini-DIN 4-pin), Audio (Phono jack)]
- ③ PARALLEL REMOTE (modular connector)
- ④ RGB/COMPONENT [BNC, Audio (Phono jack)]
- ⑤ EXY SYNC In/Out (BNC)
- ⑥ OPTION Audio In (Phono jack)
- ⑦ OPTION In connector for SD-SDI board (BKM-320D)
- ⑧ HDMI (with a cable holder)



LMD-1530W

Full compatibility
with professional HD equipment

Easy connection
with consumer products



//Operational Convenience

Marker Settings

LUMA entry-level monitors can display various area markers, including a center marker and aspect markers. The brightness of these markers can be selected from three different levels: white, gray, and dark gray. Users can also select either a black or gray matte to fill the outer area of the aspect markers. These flexible marker controls, together with the choice of many different aspect markers, make these monitors extremely convenient display devices for a variety of shooting scenarios.



4:3 aspect marker image

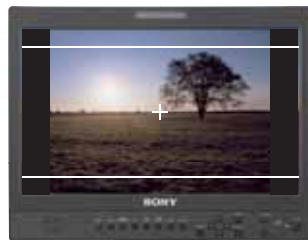

16:9 aspect marker image

Selectable Scan Size for Video Input and Aspect Ratio

With LUMA entry-level type monitors, the scan size can be selected from 5% over-scan and -3% under-scan modes. The aspect ratio can be switched between 16:9 and 4:3 according to the input signal.

Three-color Tally

LUMA entry-level type monitors are equipped with a tally lamp that can be lit via a parallel remote connector. The status of the signal displayed on the monitor can be identified by the tally color: red, green, or amber.

Parallel Remote Control

These entry-level type LUMA monitors can be controlled remotely via their parallel remote connectors. In the remote menu, there are 17 functions for the LMD-2030W and LMD-1530W, of which seven can be allocated to the remote connector.

Monaural Audio Monitoring

LUMA entry-level type monitors are equipped with a speaker (0.5 W), which enables the user to monitor audio.

Protected Controls

With LUMA entry-level type monitors, the key-inhibit function helps prevent inadvertent operation from the control panel.

//Convenient Installation

Mounting Flexibility

Mountable in a 19-inch EIA Standard Rack

LUMA entry-level type monitors can be mounted in a 19-inch EIA standard rack using optional mounting brackets. The 9U-high LMD-2030W uses MB-529 Mounting Brackets, and the 7U-high LMD-1530W uses MB-533 Mounting Brackets.



VESA Mounting

VESA standard mounting holes (100 x 100 mm pitch) are provided on LUMA entry-level type monitors to enable wall or ceiling installation.

//Other Features

- Setup level for analog component and NTSC/PAL signals
- Blue-only mode
- External sync IN

Optional Accessories



BKM-250TG
3G/HD/SD-SDI Input Adaptor
(for LMD-2451W/LMD-1751W only)



BKM-244CC
HD/SD-SDI Closed Caption Adaptor
(for high-grade type)



BKM-243HS
HD/SD-SDI Input Adaptor
(for high-grade type)



BKM-220D
SD-SDI 4:2:2 Input Adaptor
(for high-grade type)



BKM-229X
Analog Component Adaptor
(for high-grade type)



BKM-227W
NTSC/PAL Input Adaptor
(for high-grade type)



SU-561
Mounting Stand (for LMD-1751W)



MB-529
Mounting Bracket
(for LMD-2050W and LMD-2030W)



MB-530
Mounting Bracket
(for LMD-1751W)



MB-531
Mounting Bracket (for LMD-940W)



MB-532
Mounting Panel (for LMD-940W)



VF-510
ENG Kit (Viewing Hood, Carrying Handle and Connector Protector) (for LMD-940W)



BKM-320D
SD-SDI Input Adaptor
(for LMD-2030W and LMD-1530W)



MB-533
Mounting Bracket
(for LMD-1530W)

Feature Comparison

High-grade type					
Model No.	LMD-4250W	LMD-2451W	LMD-2050W	LMD-1751W	LMD-940W
Panel type	a-Si TFT Active Matrix				
Picture size*1	42-inch	24-inch	20-inch	17-inch	9-inch
Resolution (pixels)	1920 x 1080	1920 x 1200	1680 x 1050	1280 x 768	800 x 480
Aspect ratio	16:9	16:10		15:9	
Colors	Approx. 16.7 million colors				
Input interface					
Composite	BNC (x1), Optional BKM-227W BNC (x1)				BNC (x1)
Y/C	Mini-DIN 4-pin (x1), Optional BKM-227W Mini-Din 4-pin (x1)				-
RGB/Component	BNC (x3), Optional BKM-229X BNC (x3)				-
SD-SDI	Optional BKM-220D BNC (x2)				BNC (x1)
HD/SD-SDI	Optional BKM-243HS, BKM-244CC BNC (x2)				
3G/HD/SD-SDI	-	Optional BKM-250TG BNC (x2)	-	Optional BKM-250TG BNC (x2)	
HDMI	-				HDMI (x1)
DVI-D	DVI-D (x1)				-
HD15	D-sub 15-pin (x1)				-
Audio	Phono jack (x2) (L/R)				Stereo mini jack (x1)
External sync	BNC (x1), Optional BKM-229X BNC (x1)				-
Option slot	2 slots (BKM-220D, BKM-227W, BKM-229X, BKM-243HS, BKM-244CC, BKM-250TG*3)				-
Output interface					
Composite	BNC (x1)*2, Optional BKM-227W BNC (x1)*2				BNC (x1)
Y/C	Mini-DIN 4-pin (x1)*2, Optional BKM-227W Mini-Din 4-pin (x1)*2				-
RGB/Component	BNC (x3)*2				-
SD-SDI	Optional BKM-220D BNC (x1)*2				BNC (x1)
HD/SD-SDI	Optional BKM-243HS, BKM-244CC BNC (x1)*2				
3G/HD/SD-SDI	-	Optional BKM-250TG BNC (x2)	-	Optional BKM-250TG BNC (x2)	
External Sync	BNC (x1)*2				-
Audio monitor out	Phono jack (x2) (L/R)				Stereo mini jack (x1)
Speaker (Built-in)	1.0 W + 1.0 W (stereo)				0.5 W (mono)
Headphone output	-				Stereo mini jack (x1)
Remote control					
Parallel remote	Modular connector 8-pin (x1), (pin-assignable)				
Serial remote	D-sub 9-pin (RS-232C) (x1), RJ-45 modular connector (Ethernet) (x1) (10BASE-T/100BASE-TX)				RJ-45 modular connector (Ethernet) (x1)
Features					
Signal Processing	10-bit				
Color Matching	ChromaTRU				
Auto white balance calibration	-	Yes	-	Yes	Yes*4
I/P mode selection	3 modes (Inter field, Field merge, Line doubler)				
Power saving mode	Yes				
Markers	Aspect, Center, Safety Area				Aspect, Center
Waveform monitor	-	Yes			
Audio level meter	-	2-ch and 8-ch*5 SDI-embedded audio	2-ch SDI-embedded audio	2-ch and 8-ch*5 SDI-embedded audio	2-ch and 8-ch SDI-embedded audio
Color Temperature	D65, D93, user				
Closed Caption	EIA608 (standard), EIA708 (optional BKM-244CC)				-
Aspect Switch	16:9, 4:3				
Scan mode	Normal (0%), Over (5%), Native*6	Normal (0%), Over (5%), Full*6, Native*6			
Blue only	Yes				
H/V Delay	Yes				
Tally	-	3 colors			
Smart APA	Yes				-
EIA 19-inch Rack Mounting	-	Optional MB-529	Optional MB-530	Optional MB-531	
VESA Mounting	400 x 400 mm	100 x 100 mm	100 x 100 mm	100 x 100 mm 75 x 75 mm	-
Desktop stand	-	Supplied	Supplied	Optional SU-561	Supplied
DC Operation	-	24 V		12 V	12 V

*1 Viewable area, measured diagonally.

*2 Loop-through, automatic termination.

*3 3G-SDI does not support in LMD-4250W and LMD-2050W

*4 The LMD-940W supports this function from V1.05 or later.

*5 The 8-ch audio level meter can be displayed when the optional BKM-250TG input adaptor is installed.

*6 The full scan and native scan modes work on specific signal formats.

Entry-level type		
Model No.	LMD-2030W	LMD-1530W
Panel type	a-Si TFT Active Matrix	
Picture size (diagonal*1)	20-inch	15.3-inch
Resolution (pixels)	1680 x 1050	1280 x 768
Aspect ratio	16:10	15:9
Colors	Approx. 16.7 million colors	
Input interface		
Composite	BNC (x1)	
Y/C	Mini-DIN 4-pin (x1)	
RGB/Component	BNC (x3)	
SD-SDI	Optional BKM-320D BNC (x1)	
HDMI	HDMI (x1)	
DVI-D	via HDMI (x1)*1	
HD15	-	
Audio	Phono jack (x1)	
External sync	BNC (x1)	
Option connector	D-sub 9-pin (for BKM-320D) Phono jack (x1)	
Output interface		
Composite	BNC (x1)*2	
Y/C	Mini-DIN 4-pin (x1)*2	
RGB/Component	BNC (x3)*2	
External Sync	BNC (x1)*2	
Audio monitor out	Phono jack (x1)	
Speaker (Built-in)	0.5 W (mono)	
Remote control		
Parallel remote	Modular connector 8-pin (x1), (pin-assignable)	
Features		
Signal Processing	8-bit	10-bit
I/P mode selection	2 modes (Inter field, Line doubler)	
Markers	Aspect, Center	
Color Temperature	High, Low, User	
Aspect Switch	16:9, 4:3	
Scan	Under (-3%), Over (5%), Full	
Blue only	Yes	
Tally	3 colors	
EIA 19-inch Rack Mounting	Optional MB-529	Optional MB-533
VESA Mounting	100 x 100 mm	
Desktop stand	Supplied	Supplied
DC Operation	-	

*1 DVI-D/HDMI conversion cable is required.

*2 Loop-through, automatic termination.

Specifications

High-grade type



LMD-4250W



LMD-2451W

Picture Performance		
Type	α-Si TFT Active Matrix LCD	
Resolution	1920 x 1080 pixels (Full HD)	1920 x 1200 pixels (WUXGA)
Effective Picture Size(H x W) (Diagonal)	930 x 523 mm (36 3/4 x 20 3/4 inches) 1067 mm (Approx. 42 inches)	518.4 x 324.0 mm (20 1/2 x 12 7/8 inches) 613.2 mm (24 1/4 inches)
Aspect	16:9	
Colors	Approx. 16.7 million colors	
Viewing Angle	88°/88°/88°/88° (typical) (up/down/left/right contrast>10:1)	89°/89°/89°/89° (typical)(up/down/left/right contrast >10:1)
Input		
Composite	BNC (x1), 1.0 Vp-p ±3dB sync negative	
Y/C	Mini DIN 4-pin (x1) Y: 1.0 Vp-p ± 3dB sync negative, C: 0.286 Vp-p ± 3dB (NTSC burst signal level), 0.3 Vp-p ± 3dB (PAL burst signal level)	
RGB, Component	BNC (x3) RGB : 0.7 Vp-p ± 3dB (Sync On Green, 0.3 Vp-p sync negative) Component : 0.7 Vp-p ± 3dB (75% chrominance standard color bar signal)	
SDI	-	
HDMI	-	
DVI-D	DVI-D (x1) TMDS single link	
HD15	D-sub 15-pin (x1), R/G/B: 0.7 Vp-p sync positive (Sync On Green, 0.3 Vp-p sync negative) Sync : Total level (polarity free, H/V separate sync) Plug & Play function : corresponds to DDC2B	
Audio	Phono jack (x2) (L, R), -5 dBu 47 kilohms or higher	
External Sync	BNC (x1) 0.3 Vp-p to 4.0 Vp-p ± bipolarity ternary or negative polarity binary	
Option slot	2 slots Signal format: H: 15 kHz to 45 kHz, V: 48 Hz to 60 Hz	
Parallel remote	Modular connector 8-pin (x1) (Pin-assignable)	
Serial remote	D-sub 9-pin (RS-232C) (x1), RJ-45 modular connector (ETHERNET) (x1) (10BASE-T/100BASE-TX)	
DC in	-	DC 24 V (output impedance 0.05 ohms or less)
Output		
Composite	BNC (x1), Loop-through, with 75 ohms automatic termination	
Y/C	Mini DIN 4-pin (x1) Loop-through, with 75 ohms automatic termination	
RGB, Component	BNC (x3), Loop-through, with with 75 ohms automatic termination	
SDI	-	
External Sync	BNC (x1), Loop-through, with 75 ohms automatic termination	
Audio monitor out	Phono jack x 2 (L, R)	
Speaker (Built-in)	1.0 W + 1.0 W (stereo)	
Headphones output	-	
General		
Power Requirement	AC 100 V to 240 V, 50/60 Hz, 2.3 A to 1.1 A	AC 100 V to 240 V, 50/60 Hz, 1.5 A to 0.7 A DC 24 V, 5.7 A
Power Consumption	Maximum: approx. 230 W (with 2 x BKM-229X)	Maximum: approx. 130 W (with 2 x BKM-229X)
Operating Temperature	0°C to 35°C (32°F to 95°F) Recommended: 20°C to 30°C (68°F to 86°F)	
Operating Humidity	30% to 85% (no condensation)	
Storage / Transport Temperature	-20°C to +60°C (-4°F to +140°F)	
Storage / Transport Humidity	0% to 90%	
Operating / Storage / Trans. Pressure	700 hPa to 1060 hPa	
Dimensions (W x H x D) (with stand)	-	602.4 x 497.9 x 269.9 mm (23 3/4 x 19 5/8 x 10 3/4 inches)
Dimensions (W x H x D) (without stand)	1027 x 616 x 130 mm (40 1/2 x 24 3/8 x 5 1/8 inches)	602.4 x 386.2 x 110.0 mm (23 3/4 x 15 1/4 x 4 3/8 inches)
Mass (with options)	25 kg (55 lb 2 oz) (with 2 x BKM-229X)	11.4 kg (25 lb 2 oz) (with 2 x BKM-229X)
Mass	24.5 kg (54 lb)	11.0 kg (24 lb 4 oz)
Supplied accessories	AC power cord (1), AC plug holder (1), Operating Instructions (1), CD-ROM (1), Using the CD-ROM Manual (1), Warranty book (1)	

High-grade type



LMD-2050W



LMD-1751W



LMD-940W

Picture Performance			
Type	α-Si TFT Active Matrix LCD		
Resolution	1680 x 1050 pixels (WSXGA+)	1280 x 768 pixels (WXGA)	800 x 480 pixels (WVGA)
Effective Picture Size(H x W) (Diagonal)	433.4 x 270.9 mm (17 1/8 x 10 3/4 inches) 511.1 mm (20 1/8 inches)	370 x 222 mm (14 5/8 x 8 3/4 inches) 431 mm (17 inches)	195 x 117 mm (7 3/4 x 4 5/8 inches) 227 mm (9 inches)
Aspect	16:10		15:9
Colors	Approx. 16.7 million colors		
Viewing Angle	89°/89°/89°/89° (typical) (up/down/left/right contrast>10:1)	85°/85°/85°/85° (typical) (up/down/left/right contrast>10:1)	85°/85°/85°/85° (typical) (up/down/left/right contrast>10:1)
Input			
Composite	BNC (x1), 1.0 Vp-p ±3dB sync negative		
Y/C	Mini DIN 4-pin (x1) Y: 1.0 Vp-p ± 3dB sync negative, C: 0.286 Vp-p ± 3dB (NTSC burst signal level), 0.3 Vp-p ± 3dB (PAL burst signal level)		-
RGB, Component	BNC (x3) RGB : 0.7 Vp-p ± 3dB (Sync On Green, 0.3 Vp-p sync negative) Component : 0.7 Vp-p ± 3dB (75% chrominance standard color bar signal)		-
SDI	-		BNC (x1)
HDMI	-		HDMI (x1)
DVI-D	DVI-D (x1) TMDS single link		-
HD15	D-sub 15-pin (x1), R/G/B: 0.7 Vp-p sync positive (Sync On Green, 0.3 Vp-p sync negative) Sync : Total level (polarity free, H/V separate sync) Plug & Play function : corresponds to DDC2B		-
Audio	Phono jack (x2) (L, R), -5 dBu 47 kilohms or higher		Stereo mini jack (x1), -5 dBu 47 kΩ or higher
External Sync	BNC (x1) 0.3 Vp-p to 4.0 Vp-p ± bipolarity ternary or negative polarity binary		-
Option slot	2 slots Signal format: H: 15 kHz to 45 kHz, V: 48 Hz to 60 Hz		-
Parallel remote	Modular connector 8-pin (x1) (Pin-assignable)		
Serial remote	D-sub 9-pin (RS-232C) (x1), RJ-45 modular connector (ETHERNET) (x1) (10BASE-T/100BASE-TX)		RJ-45 modular connector (Ethernet) (x1) (10BASE-T/100BASE-TX)
DC in	DC 24 V (output impedance 0.05 ohms or less)	DC 12 V (output impedance 0.05 ohms or less)	DC 12 V (output impedance 0.05 ohms or less)
Output			
Composite	BNC (x1), Loop-through, with 75 ohms automatic termination		
Y/C	Mini DIN 4-pin (x1) Loop-through, with 75 ohms automatic termination		-
RGB, Component	BNC (x3), Loop-through, with with 75 ohms automatic termination		-
SDI	-		BNC (x1), output signal amplitude: 800 mVp-p ±10%, output impedance: 75 ohms unbalanced
External Sync	BNC (x1), Loop-through, with 75 ohms automatic termination		-
Audio monitor out	Phono jack x 2 (L, R)		Stereo mini jack (x1)
Speaker (Built-in)	1.0 W + 1.0 W (stereo)		0.5 W (mono)
Headphones output	-		Mini jack (x1)
General			
Power Requirement	AC 100 V to 240 V, 50/60 Hz, 0.8 A to 0.4 A, DC 24 V 3.3 A	AC 100 V to 240 V, 50/60 Hz, 0.8 A to 0.4 A DC 12 V, 5.7 A	AC 100 V to 240 V, 50/60 Hz, 0.4 A to 0.2 A, DC 12 V 1.9 A
Power Consumption	Maximum approx. 95 W (with 2 x BKM-229X)	Maximum: approx. 77 W (with 2 x BKM-229X)	Maximum approx. 24 W
Operating Temperature	0°C to 35°C (32°F to 95°F) Recommended: 20°C to 30°C (68°F to 86°F)		0°C to 40°C (32°F to 104°F) Recommended: 20°C to 30°C (68°F to 86°F)
Operating Humidity	30% to 85% (no condensation)		
Storage / Transport Temperature	-20°C to +60°C (-4°F to +140°F)		
Storage / Transport Humidity	0% to 90%		
Operating / Storage / Trans. Pressure	700 hPa to 1060 hPa		
Dimensions (W x H x D) (with stand)	518.5 x 444.1 x 269.9 mm (20 1/2 x 17 1/2 x 10 3/4 inches)	439.5 x 385.7 x 269.9 mm (17 3/8 x 15 1/4 x 10 3/4 inches) (stand is optional)	222.4 x 183.5 x 161.8 mm (8 7/8 x 7 1/4 x 6 3/8 inches) (when AC adaptor is attached)
Dimensions (W x H x D) (without stand)	518.5 x 328.7 x 104.7 mm (20 1/2 x 13 x 4 1/8 inches)	439.5 x 284.0 x 105.0 mm (17 3/8 x 11 1/4 x 4 1/4 inches)	222.4 x 166 x 70 mm (8 7/8 x 6 5/8 x 2 7/8 inches) (when AC adaptor is detached)
Mass (with options)	10.5 kg (23 lb 2 oz) (with 2 x BKM-229X)	8.8 kg (19 lb 6 oz) (with SU-561 and 2 x BKM-229X)	2.6 kg (5 lb 12 oz) (When AC adaptor is installed)
Mass	10.1 kg (22 lb 4 oz)	6.3 kg (13 lb 14 oz)	2.0 kg (4 lb 6 oz)
Supplied accessories	AC power cord (1), AC plug holder (1), Operating Instructions (1), CD-ROM (1), Using the CD-ROM Manual (1), Warranty book (1)		AC power cord (1), AC plug holder (1), AC power adaptor (1), Operating instructions (1), CD-ROM (1), Using the CD-ROM manual (1), Warranty book (1)

Entry-level type



LMD-2030W



LMD-1530W

Picture Performance	
Type	a-Si TFT Active Matrix LCD
Resolution	1680 x 1050 pixels (WSXGA+)
Effective Picture Size(H x W) (Diagonal)	433 x 271 mm (17 1/8 x 10 3/4 inches) 511 mm (20 1/8 inches)
Aspect	16:10
Colors	Approx. 16.7 million colors
Viewing Angle	89°/89°/89°/89° (typical) (up/down/left/right contrast>10:1)
Input	
Composite	BNC (x1), 1.0 Vp-p ±3dB sync negative
Y/C	Mini DIN 4-pin (x1) Y: 1.0 Vp-p ± 3dB sync negative, C: 0.286 Vp-p ± 3dB (NTSC burst signal level), 0.3 Vp-p ± 3dB (PAL burst signal level)
RGB, Component	BNC (x3) RGB : 0.7 Vp-p ± 3dB (Sync On Green, 0.3 Vp-p sync negative) Component : 0.7 Vp-p ± 3dB (75% chrominance standard color bar signal)
HDMI	HDMI (x1)
Audio	Phono jack (x2), -5 dBu 47 kilohms or higher OPTION AUDIO IN: Phono jack (x1), -5 dBu 47 kilohms or higher
External Sync	BNC (x1), 0.3 to 4 Vp-p negative polarity binary
Option In connector	D-sub 9-pin (x1), female
Parallel remote	Modular connector 8-pin (x1) (Pin-assignable)
Output	
Composite	BNC (x1), Loop-through, with 75 ohms automatic termination
Y/C	Mini DIN 4-pin (x1) Loop-through, with 75 ohms automatic termination
RGB, Component	BNC (x3), Loop-through, with with 75 ohms automatic termination
External Sync	BNC (x1), Loop-through, with 75 ohms automatic termination
Audio monitor out	Phono jack (x2), Loop-through
Speaker (Built-in)	0.5 W (mono)
General	
Power Requirement	AC 100 V to 240 V, 50/60 Hz
Power Consumption	Maximum approx. 72 W, 0.8 A to 0.4 A
Operating Temperature	0°C to 35°C (32°F to 95°F) Recommended: 20°C to 30°C (68°F to 86°F)
Operating Humidity	30% to 85% (no condensation)
Storage / Transport Temperature	-20°C to +60°C (-4°F to +140°F)
Storage / Transport Humidity	0% to 90%
Operating / Storage / Trans. Pressure	700 hPa to 1060 hPa
Dimensions (W x H x D) (with stand)	493 x 408 x 264 mm (19 1/2 x 16 1/8 x 10 1/2 inches)
Dimensions (W x H x D) (without stand)	493 x 361 x 87mm (19 1/2 x 14 1/4 x 3 1/2 inches)
Mass	9.6 kg (21 lb 3 oz)
Mass (without stand)	7.9 kg (17 lb 6 oz)
Supplied accessories	AC power cord (1), AC plug holder (1), Operating instructions (1), CD-ROM (1), Using the CD-ROM manual (1), Warranty book (1)

Dimensions

High-grade Type

LMD-4250W

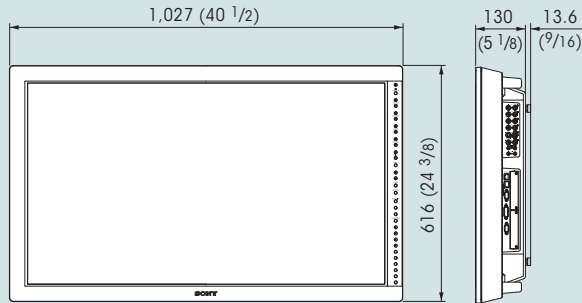

LMD-2451W

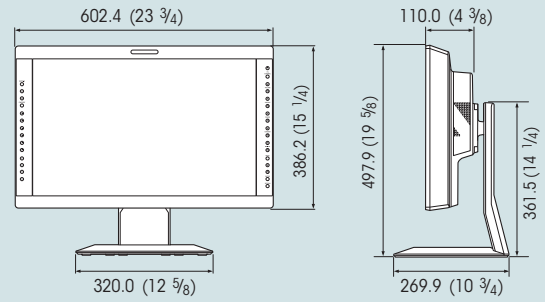

LMD-2050 W

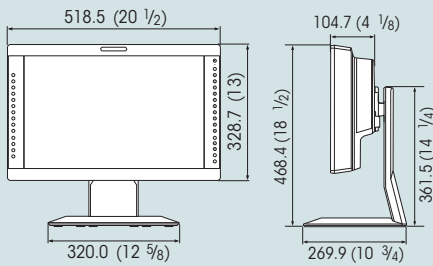

LMD-1751W

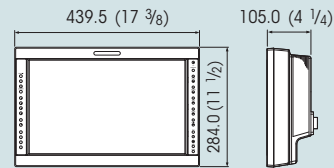

LMD-940W

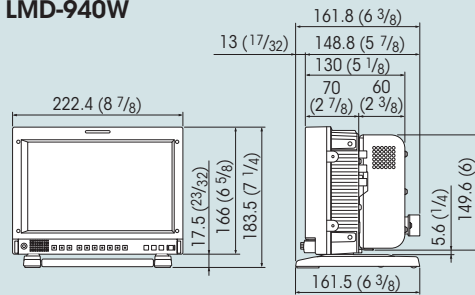

Entry-level Type

LMD-2030W

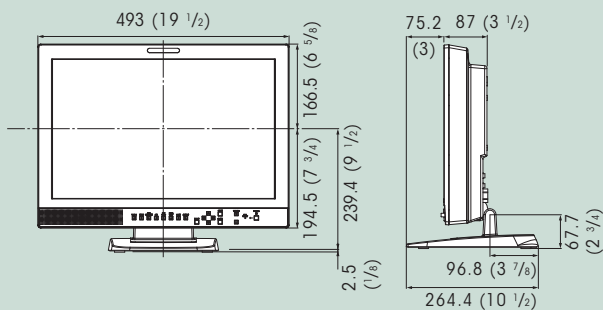

LMD-1530W

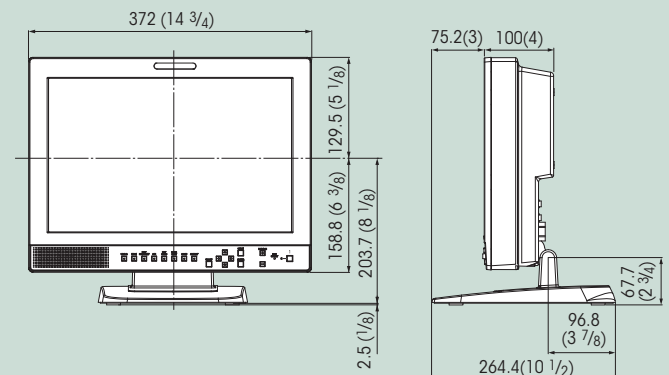



SONY

make.believe

Distributed by

©2010 Sony Corporation. All rights reserved.
Reproduction in whole or in part without written permission is prohibited.
Features and specifications are subject to change without notice.
The values for mass and dimension are approximate.
"SONY", "make.believe" are trademarks of Sony Corporation.
LUMA and ChromaTRU are trademarks of Sony Corporation.
All other trademarks are the properties of their respective owners.